

## Projectile Load Design Development and Construction comparing OCW, Ladder, Chronograph, and barrel acceleration FFT Methods for Numerical Models



Jose Simoes<sup>1</sup>, Nuno Dourado<sup>3</sup>, Doug Hart<sup>4</sup>, Eurico Seabra<sup>2</sup>

<sup>1,2</sup>Department of Mechanical Engineering, University of Minho, 4800-058 Guimarães, Portugal

<sup>3</sup>CMEMS-UMINHO, Universidade do Minho, 4800-058, Guimarães, Portugal

<sup>4</sup>Department of Mechanical Engineering, MIT, Cambridge, MA 02139, USA

**ABSTRACT** : The research and development of new materials and technologies orient the design, development, and construction of new sport optics products across the globe. With each improvement, whether in a riflescope or accessories, the final product must function without fail in the customer's hand and under the required specification conditions. Therefore, before the product is placed on the market it must be subject to a series of procedures, which involve both performing numerical analysis and physical tests to increase confidence and reliability. Numerical analyses require input data, and that must be consistent with real actions that influence the product to react. In the development of shooting equipment, the rifle recoil is considered the primary reaction for riflescopes, rifles, and accessories alike and is the most significant factor that could cause failure. For this reason, it is essential to use a load development process to have consistent energies, velocities, recoil curves, and reactions. This paper will present, discuss, and analyze the efficacy of the Optimum Charge Weight (OCW), ladder, chronograph, and barrel acceleration Fast Fourier Transform (FFT) load development methods and the results of each in load development.

**KEYWORDS** : Load development, Optimum Charge Weight, OCW, Projectile, Barrel tuning, Barrel timing

### 1 INTRODUCTION

The main reason for a custom load is shot consistency and increased accuracy. With a custom load, a shooter can tune their ammo in terms of the powder charge and overall cartridge length to obtain the best results from their gun and projectile. It is known that competitive bench rest shooters must be able to place a five-shot group within a diameter of 6.35 mm (0.250") at 91.5 m (100 yards). That would be an impossible task with factory ammo due to high bulk production processes and ammo generalization, which bring significant variations to shot consistency and accuracy[1].

There are two main methods for load development, the Optimum Charge Weight method (OCW) and the Ladder method, also known as the Creighton Audette's Ladder Test. This work aims to compare both approaches along with the Chronograph and barrel acceleration Fast Fourier Transform (FFT) based methods to verify which one is optimal and under what circumstances.

Fundamentally, load development is the process of finding the harmonics of a round with the barrel by varying one variable at a time (eg. powder charge, round length, among others). Figure 1 shows a standing sine wave with its nodes that are stationary while the anti-nodes move from one extreme to the other. Ideally, a node would be placed at the tip of the barrel so that it does not influence the trajectory of the projectile. Since this is not possible for several reasons, mainly it would make firearms impractical. The second-best option is to approximate a node as close to the barrel tip as possible and reduce the wave amplitude. Lastly, the barrel should be timed. Barrel timing or tuning is the process of systematically firing the projectile and having the vibration wave at the same position during the projectile exit. This way a systematic deflection on the projectile may be easily adjusted or compensated for using other means such as the riflescope adjustment turrets.

## Projectile Load Design Development and Construction comparing OCW, Ladder, Chronograph, and barrel acceleration FFT Methods for Numerical Models

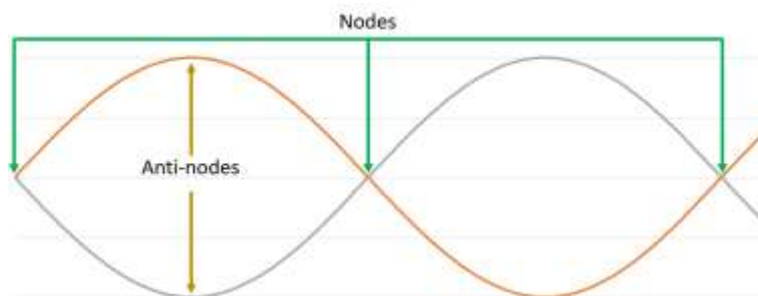

Figure 1 – Nodes and antinodes of double sine wave

Figure 2 below shows a deformed barrel with 4 nodes throughout the barrel length and an antinode at the muzzle. It should be noted that a barrel can be tuned to the load or vice versa. If a stress wave reaches a mechanical discontinuity in the object it is traveling in, such as the muzzle end of the barrel, or the butt pad, it will reflect back in the opposite direction.[2]

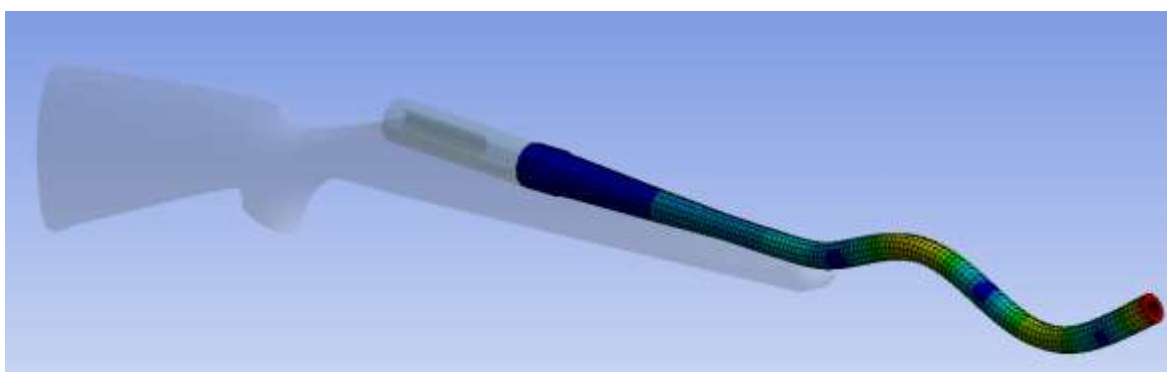

Figure 2 – Deformed barrel with 4<sup>th</sup> harmonic nodes and antinodes

After charting the data for any defined method, it is possible to find the loading charges that have small variations between its direct neighbors. These charges are also called nodes. The nodes are the ideal zones to set the reloading parameters because it is where several rounds agglomerated despite having slight variations. Consequently, this would allow slight variations during the reloading process while maintaining the required precision [1], [3].

Regardless of the used method, when deciding between two loads for accuracy and precision, the higher load should always be chosen due to the load density theory explained by RSI[4]. For further understanding, it is important to note that powder weight with regards to reloading is always given in grains worldwide, where 1 grain[gr] is equal to 0.0648 grams[g] or 1 gram[g] is equal to 15.4324 grains[gr].

### 1.1 OCW Method

The Optimum Charge Weight method (OCW) is the better-known method and was developed by Dan Newberry. It evaluates load performance at the target and is based on shot placement and precision group sizes [5].

For the OCW, the user should first select the projectile and the powder to use for testing. The only one variable should be changed at a time, in this case the powder charge. The powder or projectile manufacturer has reference tables of minimum and maximum powder quantities that should be used. A minimum of 3 rounds is required for each powder charge for grouping. The groups should start at 5-7 percent of the maximum charge and increase by one increment, or 0.3 grains [1], [5]. After reloading all rounds, testing should begin at the shooting range where each group is fired at a different target. Time should be given between shots to let the firearm cooldown so that temperature and expansion do not influence the following shots [5]. Once all groups have been fired, the targets are used to identify the group size by drawing the smallest circle possible that encompasses all shots. Figure 3 shows an example target with a 5 shot group of 40 mm in diameter. The OCW load or node would be the one with the tightest or smallest grouping while also having its neighboring loads overlap the Point of Impact (POI) [5].



**Figure 3 – Example 5 shot group with  $\varnothing$ 40 mm**

### **1.2 Ladder Method**

The Ladder Method is less known in areas other than competition shooting. The powder loads and increments are comparable to the Optimum Charge Weight method (OCW), but only one round of each charge is necessary. Once loaded all rounds should be labeled for easy identification. For testing, the rounds should all be placed on the same target and point of aim in ascending order and the Point of Impact (POI) of each should be identified. The velocity of each round should be measured with a chronograph to assist with identifying the nodes [6]–[10].

It is necessary to only account for the vertical displacement of the POIs when analyzing the target as this is directly correlated to the powder charge, any lateral displacement is due to external factors such as wind [11], [12]. Ideally, the POIs should have a rising tendency on the target and should form several small groups of at least 3 POIs. These groups are the accuracy nodes [6]–[9].

For less ideal targets, it is possible to merge the Chronograph method to the ladder method. For the Chronograph method, it is necessary to rely on the velocity data acquired from the chronograph for each round. When the velocities are charted and at least 3 consecutive projectile velocities are closer together, this would also be the velocity node, where the ideal charge weight is equal to the charge weight of the median velocity round [6]–[9].

If more than one round is fired for each charge weight, the ideal charge weight should have an extreme spread below 15 and a standard deviation in the single digits [6].

### **1.3 Acceleration FFT Method**

The acceleration Fast Fourier Transform (FFT) method is proposed in this article and is object of analysis. The method is described as follows. An accelerometer of insignificant mass, in order to not interfere in the system, is coupled to the end of the barrel. The barrel's natural frequency should be measured by impacting the barrel with a metallic rod and measuring its acceleration curves. By calculating an FFT of the measured data, the frequency with the highest peak should be the natural frequency of the barrel.

The same data recording and FFT calculation should be performed for each round.

The ideal round will have the lowest acceleration frequency in the barrel's natural frequency range.

## **2 METHODS**

There are various variables that may be changed when developing a load. These are the primer, bullet, powder, overall length, casing, and the crimp [13]. When developing a load only one variable should be changed at a time to understand its influence on the system's precision and accuracy.

Load development was performed for all load development and selection methods. The load consists of a .260 Cartridge, primer, powder, and projectile. The cartridge dimensions are shown in Figure 4.

**Projectile Load Design Development and Construction comparing OCW, Ladder, Chronograph, and barrel acceleration FFT Methods for Numerical Models**

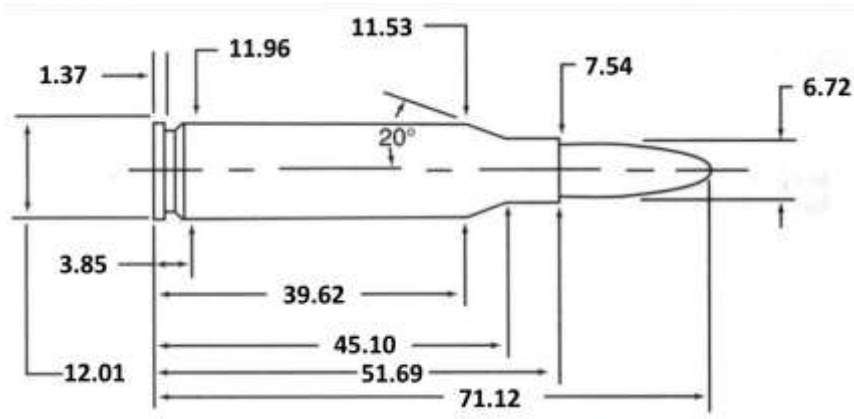

**Figure 4 - .260 Rem. cartridge dimensions[14]**

The recommended starting powder charge of 42 grains and max powder charge of 45.9 grains was referenced from the Vihtavuori data catalog [15]. Using a powder increment of 0.3 grains between loads, yielded a total of 14 different powder loads. The powder quantity in each load is shown in Table 1.

**Table 1 - Powder charge in each load (in grains)**

Load #	1	2	3	4	5	6	7	8	9	10	11	12	13	14
Powder Charge	42.0	42.3	42.6	42.9	43.2	43.5	43.8	44.1	44.4	44.7	45	45.3	45.6	45.9

**2.1 Reloading**

Reloading was done using RCBS brand dies and press. The process used is described in the most common reloading brand manuals including the RCBS and Lyman [1], a process flow chart is shown in Figure 5 and described below. In this regard, it is important to always use safe practices and keep concentration while reloading. Bob Shell suggests that incorporating feel in the reloading process can detect many abnormalities in the process that may affect cartridge accuracy.[16]

First, the brass is cleaned using an ultrasonic cleaner or tumbler to remove any carbon deposits so that these do not create indentations or gaps in the final assembly. Next, each case is lubed and re-sized using dies and a press. The cases are later trimmed to the correct length and de-burred. The cases are then pressed with a new primer, should be even with the bottom of the case.

The powder is dispensed, and its mass measured before funneling the powder into each case. It is crucial that each case has the correct amount of power, too little and the projectile could stay lodged in the barrel. Each case is then pressed with a projectile and the final length is measured for consistency. Lastly, each case or batch should be clearly labeled for identification.

## Projectile Load Design Development and Construction comparing OCW, Ladder, Chronograph, and barrel acceleration FFT Methods for Numerical Models

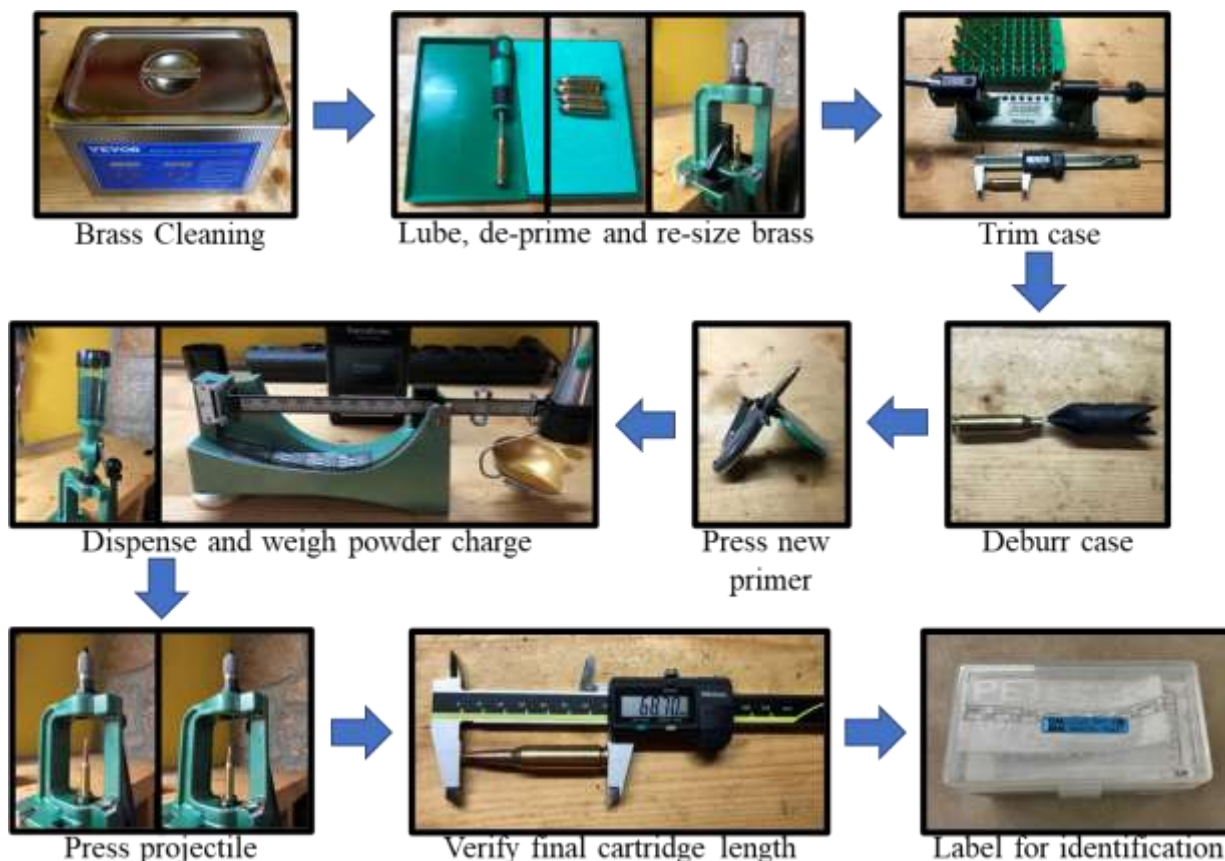

Figure 5 - Reloading process flow chart

### 2.2 Range tests

At the shooting range, the rifle was properly supported on a benchrest with sandbags. The barrel was fouled with a few shots, and the riflescope was sighted. All shots were taken at 100 meters.

For the OCW method, the group size was measured as the distance between the 2 furthest shots on target, or, in other words, the smallest diameter that fit all shots from the same group.

For the ladder method, the vertical distance from the center of the target and the point of impact of each shot was measured. This vertical displacement is used in the results to find the grouped loads and thus the optimum load. For the velocity method the projectile speed was measured using the magnetospeed [17]. Bryan Litz from Applied Ballistics compared the magnetospeed chronograph with other chronographs. In his findings, he calculated the theoretical resolution on a 914.4 m/s shot to be 0.55 m/s (+/-0.27 m/s).[18], [19]

Lastly, for the acceleration FFT method, an ADXL372Z accelerometer from ANALOG DEVICES was coupled to the end of the barrel to record the recoil vibrations and barrel movements during the tests. The ADXL372Z is a micro-electromechanical system (MEMS) 3-axis accelerometer capable of reading at a frequency of 3,200 Hz and can reliably measure up to  $\pm 200$  G [20], [21]. Over-sampling is possible up to 6,400 Hz.

The microcontroller used to acquire and save the readings to memory was the Arduino Mega along with an adapted source code provided by ANALOG DEVICES. The source code was created to be used with the Arduino Uno [22], but due to the minute available memory onboard an adaptation to the Arduino Mega was needed. The Arduino Uno could only handle 100×3 data points while the Mega's internal memory allows to save 400×3 data points. External memory could not be used as this would drastically increase the time between samples and a high data sample rate could not be achieved.

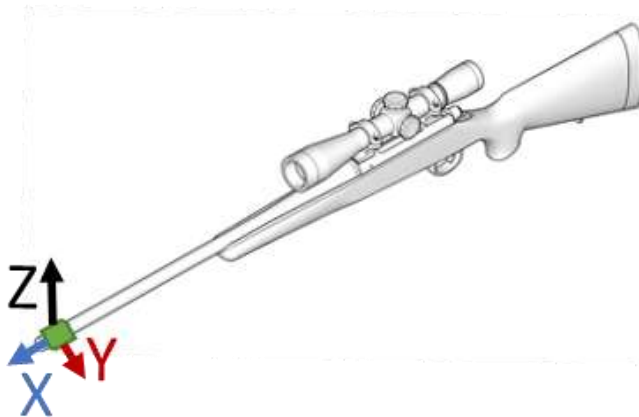

Figure 6 - Accelerometer position and orientation on the barrel

Figure 6 shows a free body diagram of the sensor on the barrel. The positive X axis is pointing in the direction of the target, the positive Y axis is toward the left of the shooter and the positive Z axis is pointing up.

The recorded acceleration data for each round will then be graphed over time. The acceleration data will also be integrated to calculate the barrel velocity. The velocity data will also be integrated to calculate the barrel deformation. The FFT analysis will then be performed to verify the dominant frequencies in the barrel through the power spectral density plot and check if any correspond to the barrel’s natural frequency.



The natural frequency of the barrel will be measured by impacting the barrel with a metallic rod, measuring the acceleration data and calculating the FFT curve. The FFT curve will indicate the frequencies present in the barrel and the one with the highest magnitude will be the dominant or natural frequency of the barrel.



Naturally, if necessary, the data may be subjected to a data filter to reduce any noise read by the sensor.

### 3 RESULTS





Table 2 shows the load along with the group size diameter (in millimeters) and the replica image of the target with the POIs.





Table 2 - OCW groups size results

Load #	Powder Charge [grains]	Group diam. Size [mm]	Target Image
1	42	126	
2	42.3	63	
3	42.6	24.5	

Load #	Powder Charge [grains]	Group diam. Size [mm]	Target Image
8	44.1	44	
9	44.4	38	
10	44.7	42.5	

**Projectile Load Design Development and Construction comparing OCW, Ladder, Chronograph, and barrel acceleration FFT Methods for Numerical Models**

Load #	Powder Charge [grains]	Group diam. Size [mm]	Target Image
4	42.9	51	
5	43.2	62	
6	43.5	33.2	
7	43.8	47.5	

Load #	Powder Charge [grains]	Group diam. Size [mm]	Target Image
11	45	55	
12	45.3	30	
13	45.6	75	
14	45.9	151	

Analyzing the targets and the group size of each, it is possible to see a node between the range of load 6 and load 12. All group sizes are below 50mm except for load 11. To choose an ideal load, the difference in group size from one load to its neighboring loads should be as small as possible. From the recorded values, load 9 is the ideal load because it is one of the tightest groups recorded and the group size difference to load 8 is 6 mm and to load 10 is 4.5 mm.

The ladder test on target was shown to be inconclusive because 3 consecutive load groups were not achieved. This could be either from user or environmental error, which is notorious while firing one shot load.

**Table 3 - Ladder test results**

Load #	Powder Charge [grains]	Vertical distance to center [mm]
1	42	-2
2	42.3	-28
3	42.6	-12
4	42.9	40
5	43.2	24
6	43.5	-25
7	43.8	16

Load #	Powder Charge [grains]	Vertical distance to center [mm]
8	44.1	-15
9	44.4	21
10	44.7	38
11	45	47
12	45.3	-19
13	45.6	66
14	45.9	74

A visual representation of the ladder method target is shown in Figure 7. The center circle has a radius of 10 mm, and the subsequent circles have an increment of 10 mm for each radius.

**Projectile Load Design Development and Construction comparing OCW, Ladder, Chronograph, and barrel acceleration FFT Methods for Numerical Models**

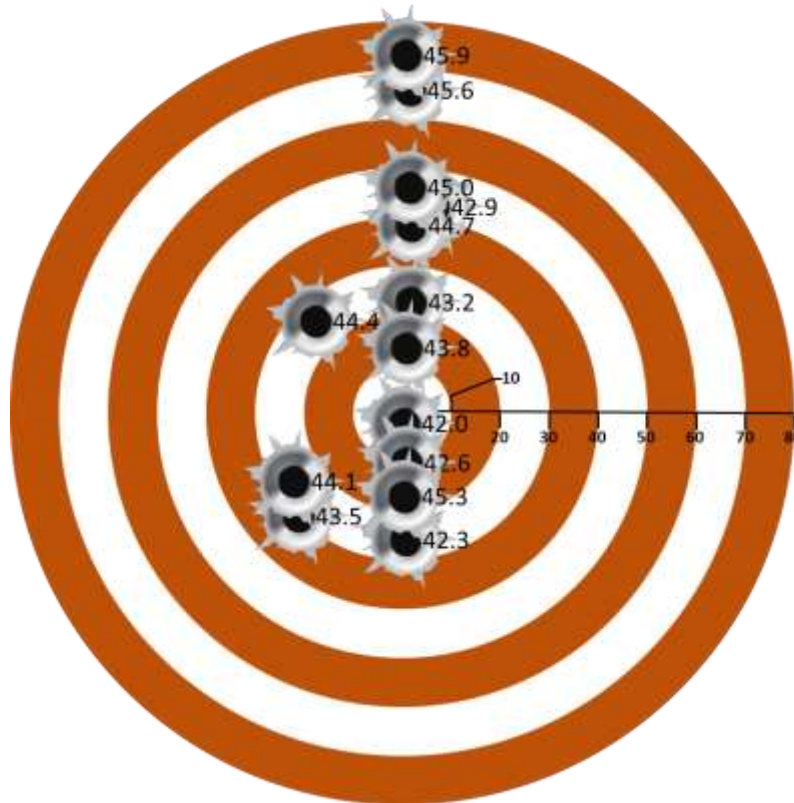

**Figure 7 - Ladder target results**

Consequently, it was necessary to analyze the velocity reading for the various loads. The velocity data shown in Table 4 is for the 3 round loads used in the OCW method. This was done to gather more data on each load and to reduce the impact of any outliers. Table 4 shows the velocity for the 3 shots of each load, along with the average and median velocities and the standard deviation of each load and corresponding range or also known as the extreme spread.

**Table 4 – Ladder Velocity results**

Load #	Powder Charge [grains]	Shot 1 [m/s]	Shot 2 [m/s]	Shot 3 [m/s]	Avg. [m/s]	Median [m/s]	SD [m/s]	Range [m/s]
1	42	819	823	817	820	819	3	5
2	42.3	814	821	822	819	821	4	8
3	42.6	815	822	828	822	822	6	12
4	42.9	836	841	833	837	836	4	8
5	43.2	829	836	837	834	836	4	8
6	43.5	854	849	849	851	849	3	5
7	43.8	853	856	853	854	853	2	3
8	44.1	859	861	863	861	861	2	5
9	44.4	865	867	866	866	866	1	2
10	44.7	883	884	908	892	884	14	25
11	45	899	904	915	906	904	8	16
12	45.3	898	900	902	900	900	2	3
13	45.6	911	907	926	915	911	10	19
14	45.9	915	913	892	907	913	13	23



## Projectile Load Design Development and Construction comparing OCW, Ladder, Chronograph, and barrel acceleration FFT Methods for Numerical Models

The velocity data for the ladder method is plotted in Figure 8 for easier understanding and visual analysis. From the chart it is possible to visualize 3 velocity nodes. The first one between loads 1 and 3 (i.e., 42.3 grains), the second between loads 6 and 9 (i.e., 43.6 and 44.4 grains), and the last between loads 13 and 14 (i.e., 45.6 and 45.9 grains).

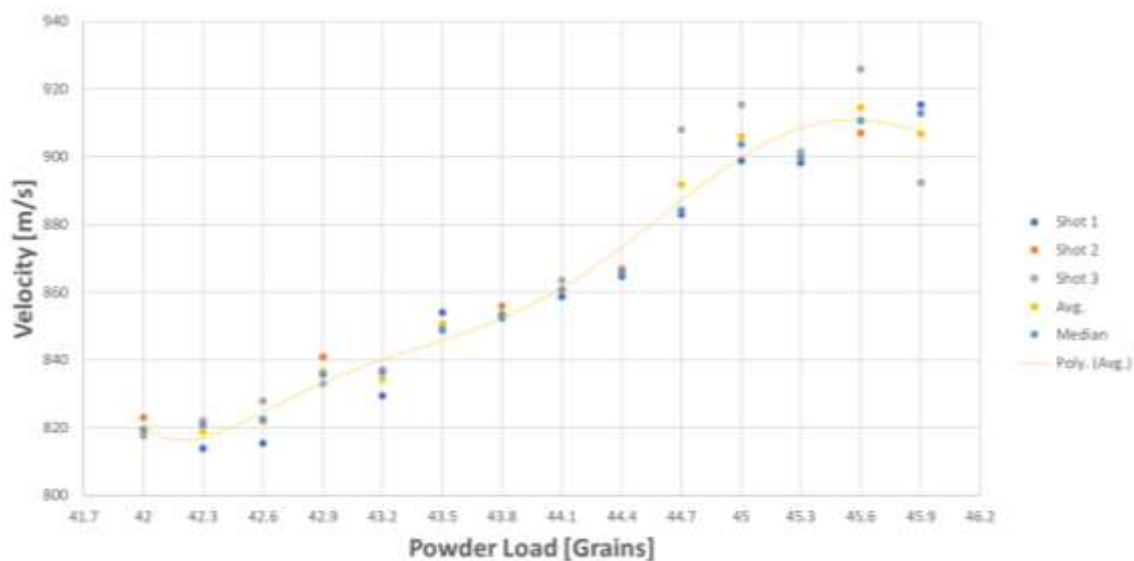

Figure 8 - Charted ladder velocity points

None of the loads that comprise the lowest node have a range lower than 15, and the higher node is only composed of 2 loads where their range is also much higher than 15. Therefore, the only viable node is the middle one, between loads 6 and 9. Load 8 would be a very forgiving load because its neighboring loads are very close and have low ranges and standard deviations. Load 9 has a much lower range of velocities and a standard deviation of 3.5 m/s which is less than 50 percent of load 8. Therefore, load 9 would be the ideal load for more consistent shooting.

For the described FFT method, the ADXL372Z accelerometer would start to record data at 5,000 Hz after suffering an impact greater than 5G. On average it takes 71.6 ms. for the maximum reading to return to below 5G.

Figure 9 shows the resultant acceleration of the 3 axes. It is possible to detect that the graph curves start out in a random manner and after about 8.2 ms the curves start to follow a channel.

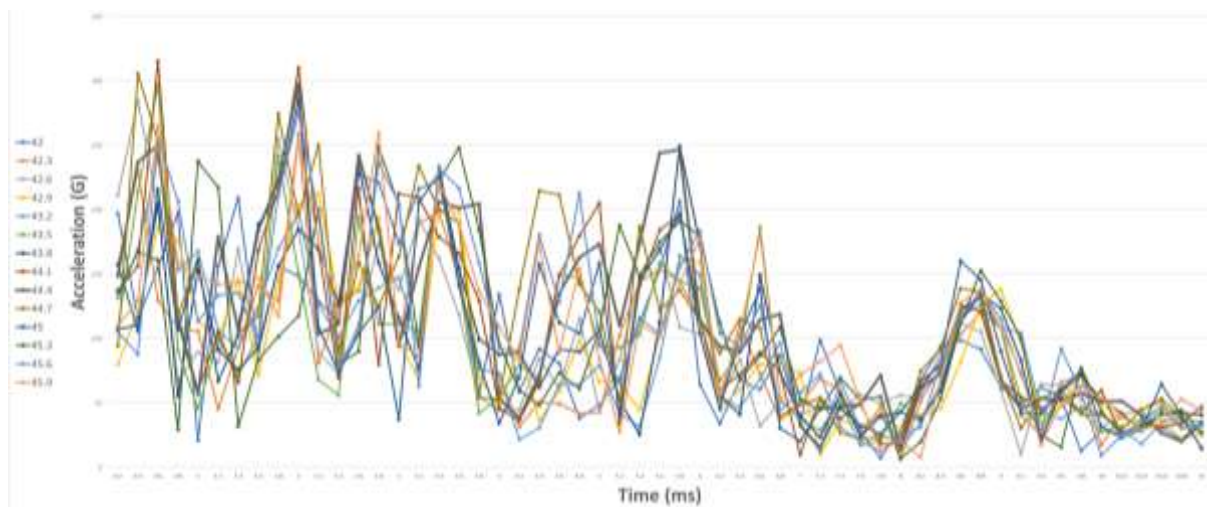
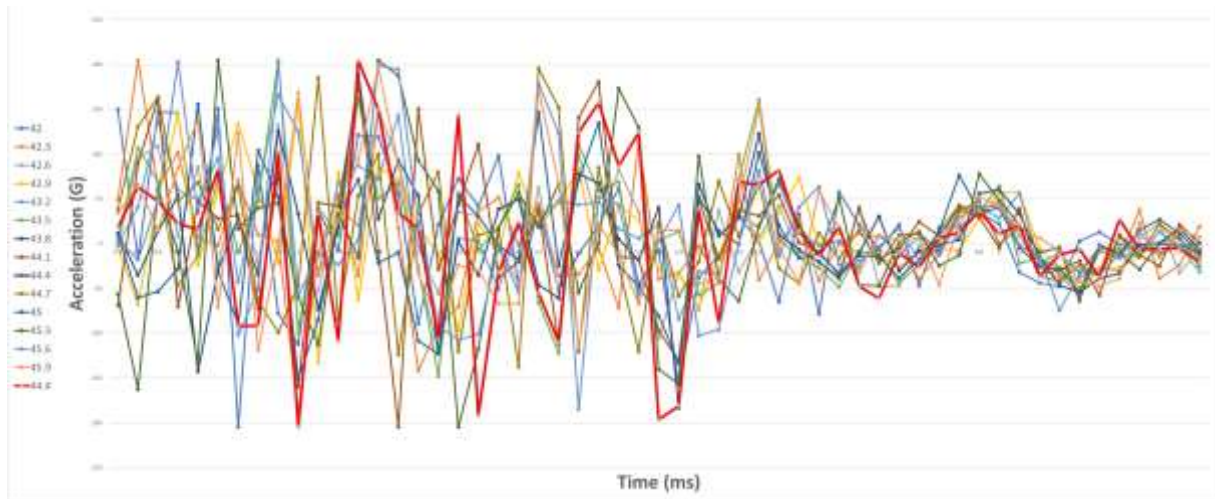

Figure 9 - Resultant tri-axial acceleration data

Figure 10 and Figure 11 show respectively the X and Y axis graphs, plotted on their own. Here it is not possible to relate any curves. The data points seem erratic thus making the graph difficult to read, interpret and derive any logical conclusions.

**Projectile Load Design Development and Construction comparing OCW, Ladder, Chronograph, and barrel acceleration FFT Methods for Numerical Models**



**Figure 10 - x-axis acceleration data**

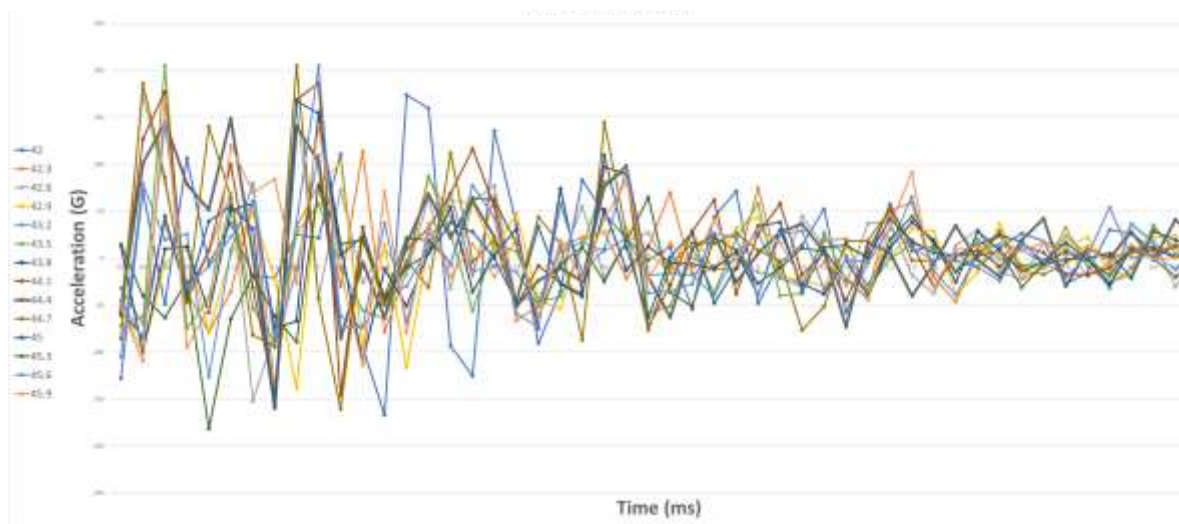

**Figure 11 - y-axis acceleration data**

On the other hand, Figure 9 illustrates the Z axis graph, here the data is very consistent between loads. Indeed, all loads follow a nice clean channel, the curves are smooth and well defined.

# Projectile Load Design Development and Construction comparing OCW, Ladder, Chronograph, and barrel acceleration FFT Methods for Numerical Models

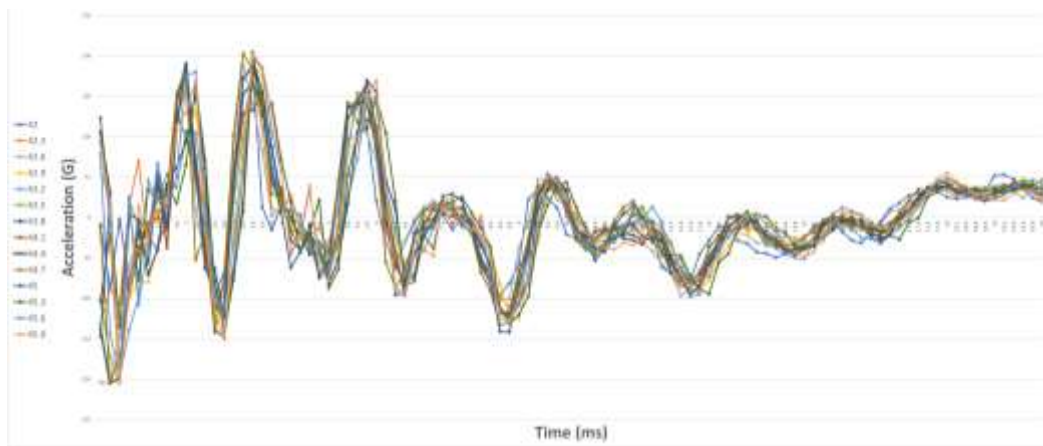

Figure 12 - z-axis acceleration data

For the FFT calculation, only the x axis was analyzed due to the nature of the data. The Y and Z axis are perpendicular to the barrel axis, while the X axis is parallel. The Z axis was not included, since it also incorporates barrel jump in the measurements. Thus, the recorded acceleration is very consistent in each round.

## 4 CONCLUSION

From the collected data results, it is possible to conclude that both the OCW and the ladder test indicate that load 9 would be the ideal and most consistent load for the setup. The Ladder Method is preferred to get a consistent shot and, in turn, allows obtaining reliable readings of recoil, acceleration, and deformation of the rifle setup. It can find the optimal load with standard deviations in the single digits.

The OCW method is not recommended as it is prone to user error during shot placement. Although, OCW can complement the ladder method when obtaining a precise group as the projectile may be deflected by the barrel harmonics, causing a large deviation at the target distance.

From a scientific point of view, the ladder method is preferred as it brings a measurable value that can be used to verify the results and to use the data in further calculations and analyses.

The erratic nature of the data points on the X and Y axis acceleration charts most probably indicates that the sampling frequency was not high enough to correctly sample all the necessary data points to correctly define the curves. The data acquisition frequency must be much higher, and it is not possible with the current setup to fully characterize the curves.

Although the data was filtered with a low pass filter at 2,500 Hz to eliminate antialiasing as the acquisition frequency is at 5,000 Hz, thus a sampling factor of 2 as required by the Nyquist -Shannon theorem. Harry Jol discuss in his work [23] the importance of using a sampling factor of 6 to minimize the data amplitude error, while Dossi et al. [24] recommended in their work to use a sampling factor of 12 for a maximum amplitude acquisition error of 5%.

Figure 13 shows the power spectral density(PSD) plots calculated using the FFT. A harmonic is shown across all curves at around 500Hz, where the optimal load of 44.4 grains happens to be the highest. 500 Hz is also a sampling factor of 10, approximate to the recommended sampling frequency by [24].

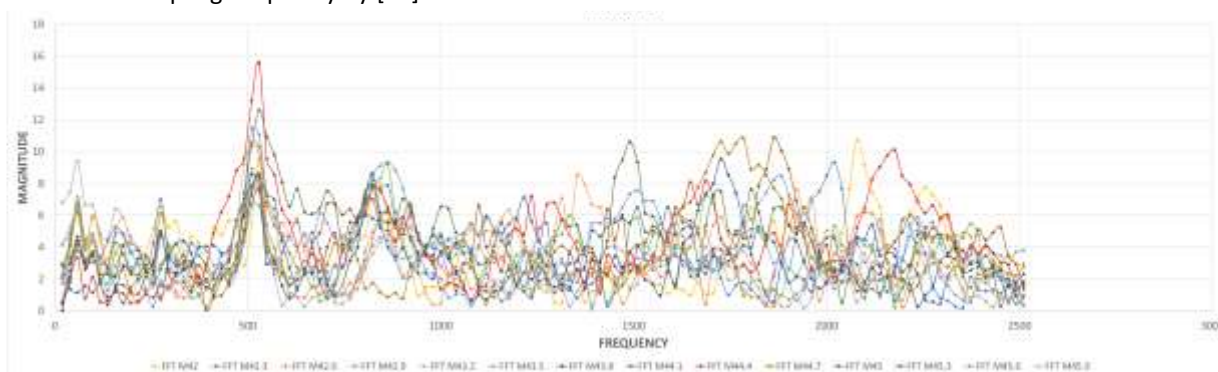

Figure 13 - FFT for the x axis data

## Projectile Load Design Development and Construction comparing OCW, Ladder, Chronograph, and barrel acceleration FFT Methods for Numerical Models

To obtain data with a larger sampling factor, the x axis data must be filtered using a Butterworth low-pass filter of 500 Hz (Figure 14) and 1,000 Hz (Figure 15) respectively, yielding a sampling factor of 10 and 5 respectively.

With lower frequencies, the acceleration curves form sinusoids and are well defined with multiple points and approximating the curve amplitude to the real-world signal amplitude. The various load curves now seem to align, like the previously shown Z axis chart in Figure 12.

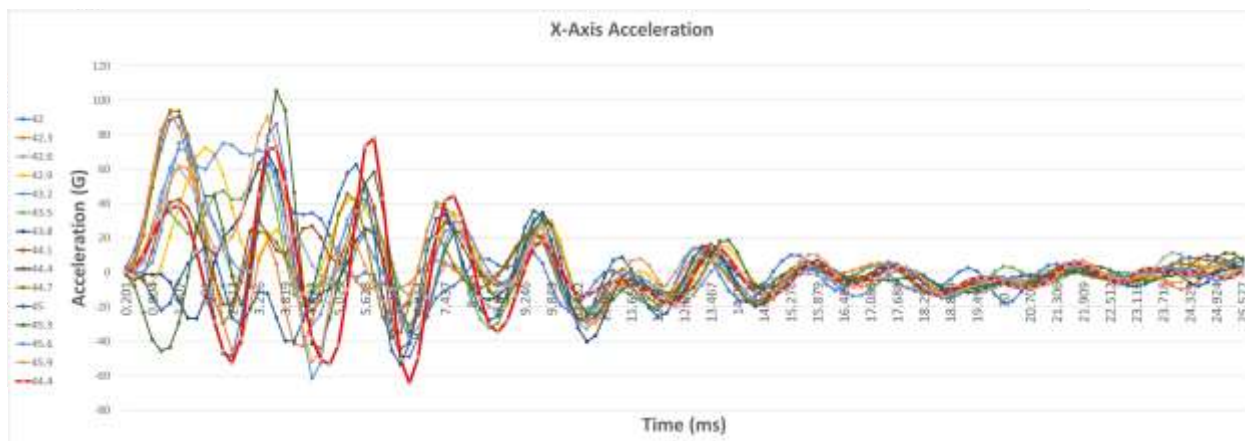

Figure 14 - x-axis acceleration with 500Hz filter

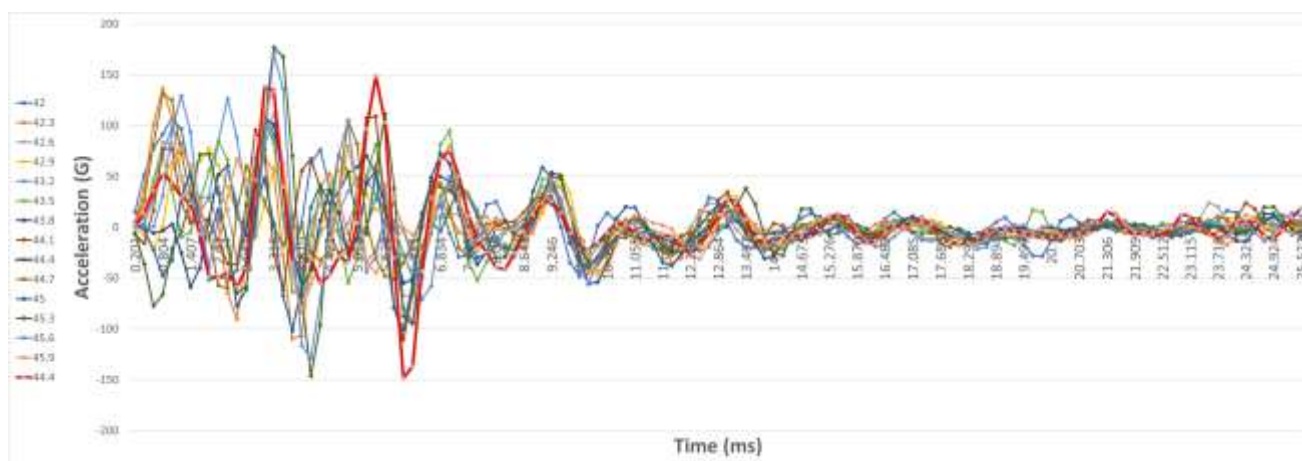

Figure 15 - x-axis acceleration with 1,000Hz filter

The z axis is consistent, and all curves form a similar pattern, a channel, over time. These acceleration curves most likely characterize the barrel movement or jump as these create a large displacement at lower frequencies.

The power spectral density (PSD) plots allow to conclude that some rounds produced vibrations at the barrel's natural frequency of 60Hz. Coincidentally, the optimal load had one of the lowest magnitudes at 60Hz.

From the barrel displacement calculation, it is possible to conclude that the 44.4 grain load had one of the smallest displacements at just 0.06mm just behind the 42.6 load at just 0.02mm of displacement. The PSD plot also showed that the 44.4 grain load tended to have higher frequency waves. Higher frequency waves have a less significant impact on displacement than low frequency, or slower moving waves.

It is interesting to note that the ideal powder charge selected in both the OCW, and Ladder methods has the peak acceleration on the x axis much later than the other charge weights, 2.6 ms compared to the others ranging from 0.4 – 1.8 ms. Thus, possibly indicating that a lagging acceleration curve improves accuracy on target.

## Projectile Load Design Development and Construction comparing OCW, Ladder, Chronograph, and barrel acceleration FFT Methods for Numerical Models

### REFERENCES

- 1) E. Matunas, B. Towsley, P. Matthews, and B. Fisher, *Lyman Reloading Handbook*, 48th ed. Middletown, CT: Lyman Products Corporation, 2002.
- 2) C. Long, "Shock Wave Theory – Rifle Internal Ballistics, Longitudinal Shock Waves, and Shot Dispersion," 2003.
- 3) J. Ristow, "Barrel Harmonics, Pressures and Timing," *Recreational Software, Inc.*, 2004. <https://www.shootingsoftware.com/barrel.htm> (accessed Jun. 18, 2020).
- 4) "RSI - Load Density." <https://www.shootingsoftware.com/loadens.htm> (accessed Jun. 18, 2020).
- 5) "OCW Instructions," *Optimal Charge Weight load development*. <http://www.ocwreloading.com/about.html> (accessed Aug. 13, 2020).
- 6) "Creighton Audette's Ladder Test - PrecisionRifleBlog.com." <https://precisionrifleblog.com/2012/07/13/creighton-audette-ladder-testing/> (accessed Feb. 07, 2021).
- 7) "7 Steps to Reloading for Better Accuracy - Western Hunter." <https://westernhunter.net/tactics/7-steps-to-reloading-for-better-accuracy/> (accessed Feb. 07, 2021).
- 8) R. Constantine, "Incremental Load Development Method," *Precision Shooting Annual*, Bayfield, CO, p. 19, 1997.
- 9) F. Sinclair and B. Gravatt, *Precision Shooting Reloading Guide*, 2nd ed. Precision Shooting, Inc., 1998.
- 10) J. D. Snyder, "Handloaded Rifle Ammunition: A Look into the Assembly Process, Load Development Methods, and Its Comparison to Factory Ammunition," University of South Carolina, 2014.
- 11) D. Periard, "Where does wind matter?," *Appl. Ballist. Sci. Accuracy*, pp. 1–7, 2021.
- 12) B. Litz, "Maximum Effective Range of Small Arms," *Appl. Ballist. Sci. Accuracy*, pp. 1–14, 2006.
- 13) A. Evans, "Load Development for Beginners," *Pew Pew Tactical*, 2017. <https://www.pewpewtactical.com/load-development-beginners/> (accessed Feb. 07, 2021).
- 14) Barnes, "260 Remington Powder Minimum Maximum."
- 15) VIHTAVUORI, *Reloading Guide 2019*. VIHTAVUORI, Finland: VIHTAVUORI, 2019.
- 16) B. SHELL, "HANDLOADING BY FEEL," *Can. FIREARMS J.*, no. FEBRUARY, 2019.
- 17) "MagentoSpeed Ballistic Chronograph – MagentoSpeed." <https://magentospeed.com/pages/reviews-tests> (accessed Oct. 27, 2020).
- 18) B. Litz and N. Vitalbo, "Measuring Muzzle Velocity Chapter 15 : Measuring Muzzle Velocity," *Appl. Ballist. Sci. Accuracy*, 2014.
- 19) B. Litz and N. Vitalbo, *Modern Advancements in Long Range Shooting: Volume 1*, vol. 3. Cedar Springs, MI: Applied Ballistics, LLC, 2014.
- 20) A. Devices, "EVAL-ADXL372Z User Guide ." •Norwood, Mar. 2017, Accessed: Feb. 12, 2022. [Online]. Available: [www.analog.com](http://www.analog.com).
- 21) A. Devices, "ADXL372 Data Sheet." Norwood, Aug. 2018, Accessed: Feb. 12, 2022. [Online]. Available: [www.analog.com](http://www.analog.com).
- 22) "Impact Measurement Demo using the Arduino Uno [Analog Devices Wiki]." [https://wiki.analog.com/resources/eval/user-guides/arduino-uno/reference\\_designs/demo\\_adxl372](https://wiki.analog.com/resources/eval/user-guides/arduino-uno/reference_designs/demo_adxl372) (accessed Feb. 12, 2022).
- 23) H. M. Jol, "Ground Penetrating Radar Theory and Applications," *Gr. Penetrating Radar Theory Appl.*, pp. 1–524, Dec. 2008, doi: 10.1016/B978-0-444-53348-7.X0001-4.
- 24) M. Dossi, E. Forte, and M. Pipan, "Minimum threshold for the sampling rate to prevent amplitude distortions in aliasing-free GPR surveys," *2018 17th Int. Conf. Gr. Penetrating Radar, GPR 2018*, Aug. 2018, doi: 10.1109/ICGPR.2018.8441579.



There is an Open Access article, distributed under the term of the Creative Commons Attribution – Non Commercial 4.0 International (CC BY-NC 4.0) (<https://creativecommons.org/licenses/by-nc/4.0/>), which permits remixing, adapting and building upon the work for non-commercial use, provided the original work is properly cited.